



-()

: -

( )

: -

: ( )

(Speed Bump) : -

( - )

( - , )

( )

( - - )

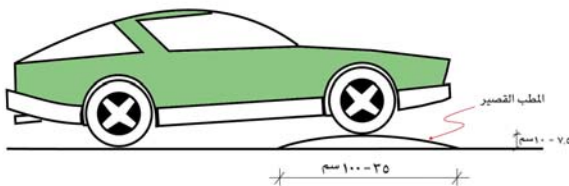

:( - - )

-

- ( )

(Speed Hump) : ( )

-

( - , )

. ( , - , )

( - - )

( - )

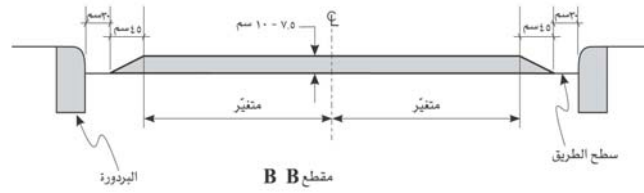
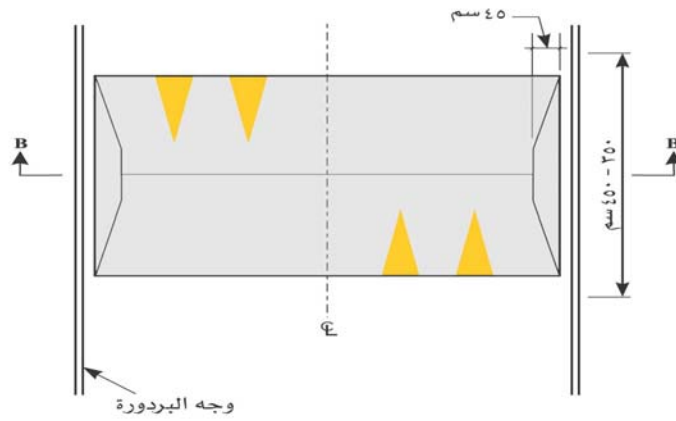

:( - - )

-

- ( )

(Speed Table) :

( - - )

( )

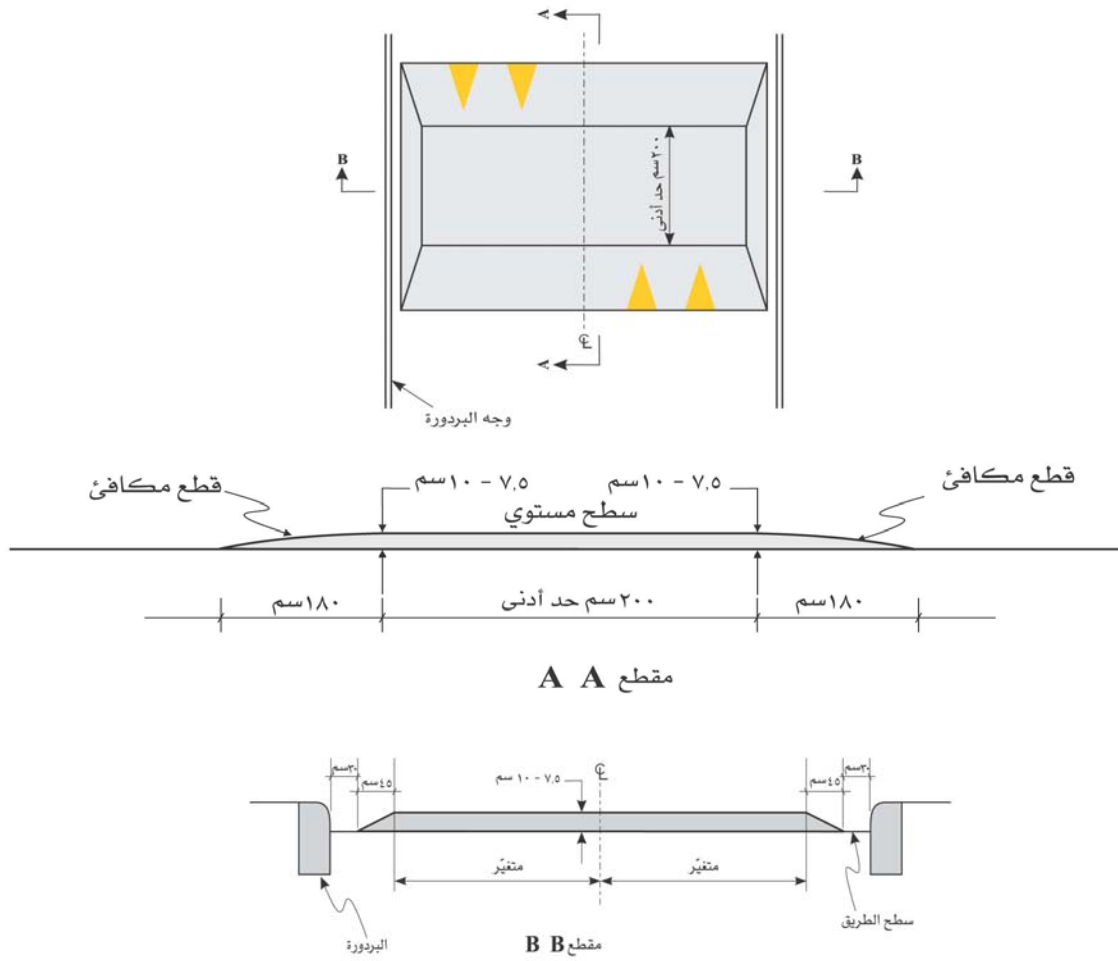

( - - ) :

- ( )

(Raised intersections) :

-

( - - )

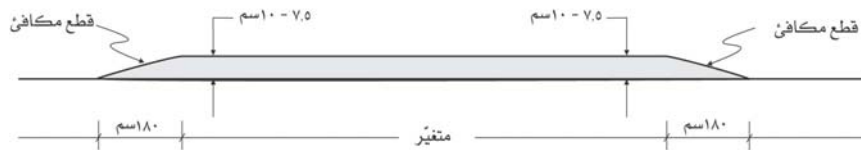
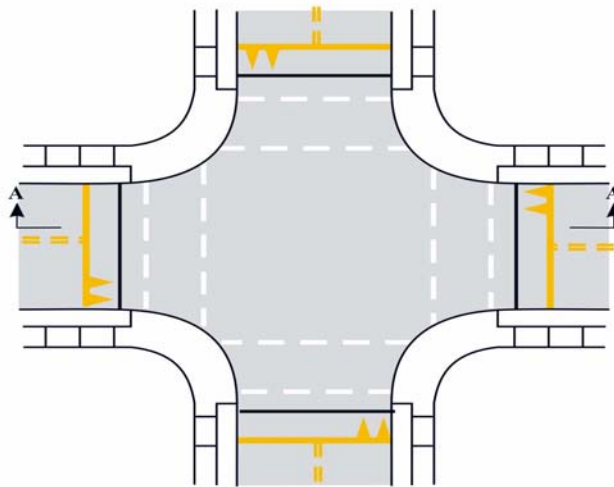
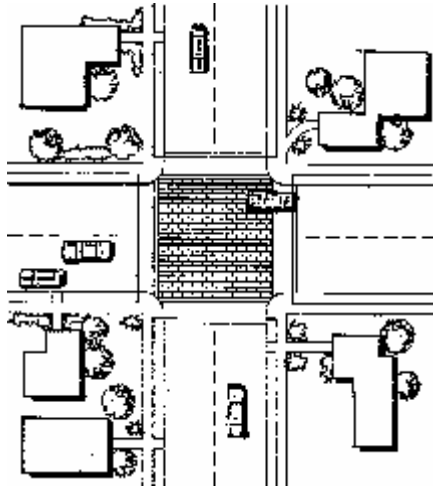

مقطع A A

( ) : ( - - )

-

-()

:

-

:

-

( )

( )

( )

( )

( - - )

:( - - )

	.( )
	.( )
	.(%)
-	.( )
.( )	.( )
	.( )

-

-()

:

-

-

-

. ( )

( )

-

-

.( : )

. ( )

-

-

:

-

-

. ( )

-

. ( )

-

( )

-

( )

-

-()

( )

( )

-

-

. ( )

-

. ( ) ( )

. ( )

-

:

-

( - - )

( : )

-



- ( )

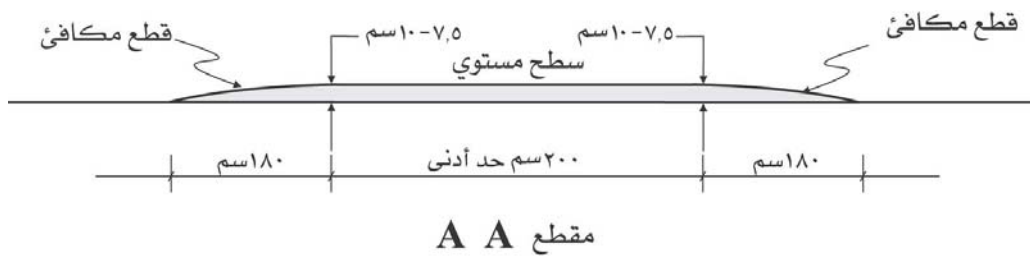
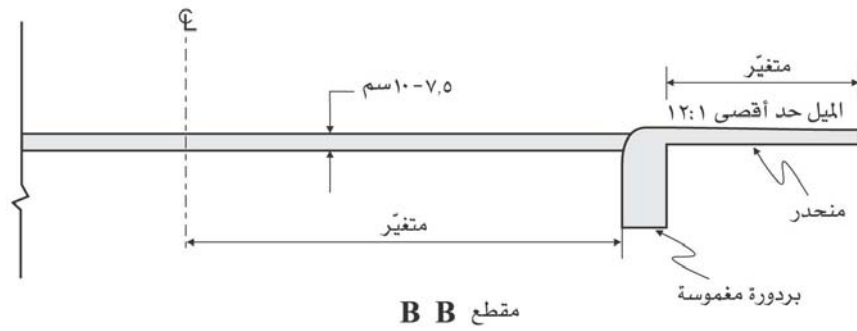
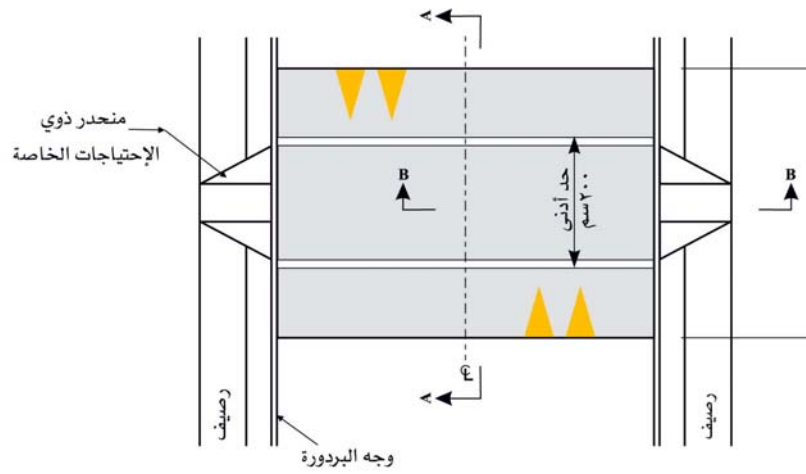

:( - - )

-( )

:

-

( )

( - , )

( - - )

( - - )

( - - ) ( - - )

:( - - )

( , - , )	( )
( )	( )
( - )	) ( ) (
: :	
:	

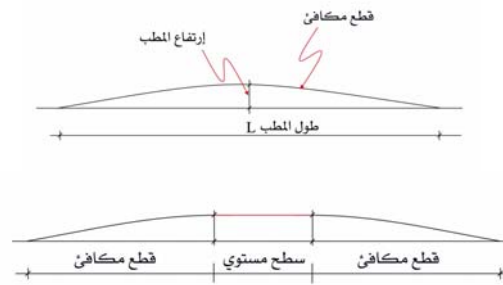

:( - - )

-

-()

, :( - - )

-	-	,		,					,
-	,	,		,	,	,			,
,	,		,						,

:( - - )

-	-		,			,			,
-		,			,				,
		,							,

( - - ) ( - - ) :

: -

: -

: - -

-

-()

: - -

:

:

- - -

()

:

- - -

. ()

)

.(

-()

:

-

:

- -

( )

:

- -

( )

:

-

:

-

- )

"

"(

" ( - - - )

.( - - )

( - - )

-

-()

:( - - )

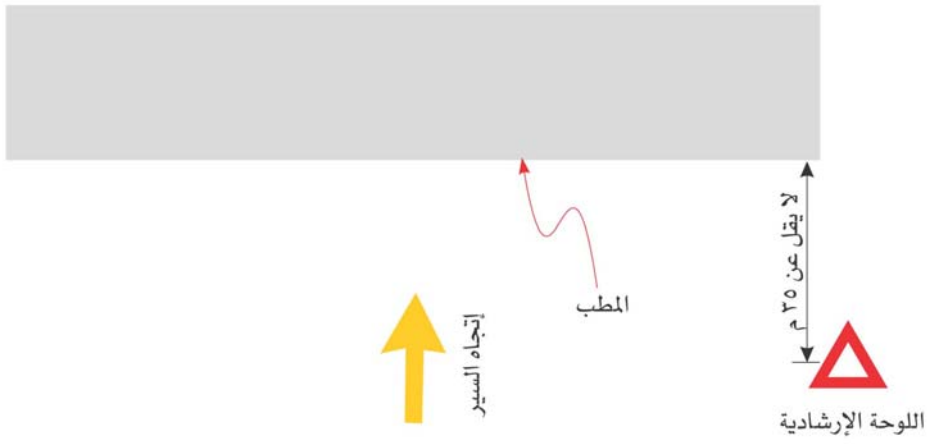



:( - - )

( - - )

( - - )

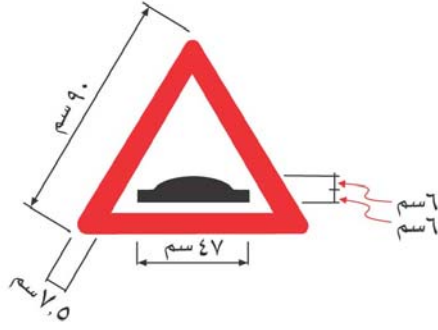
- ( )



( ) : ( - - )

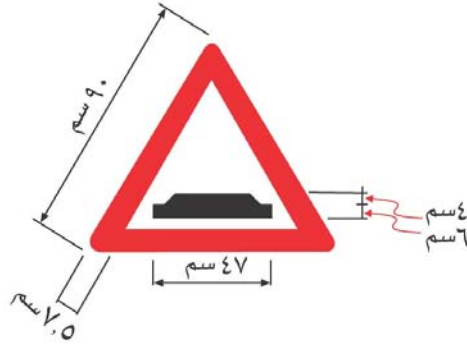

( ) : ( - - )

- :

" ( - - - )

"

" ( - - - ) "

" ( - - - )

"

:

( )

-

-

( - - ) ( - - )

-

- ( )

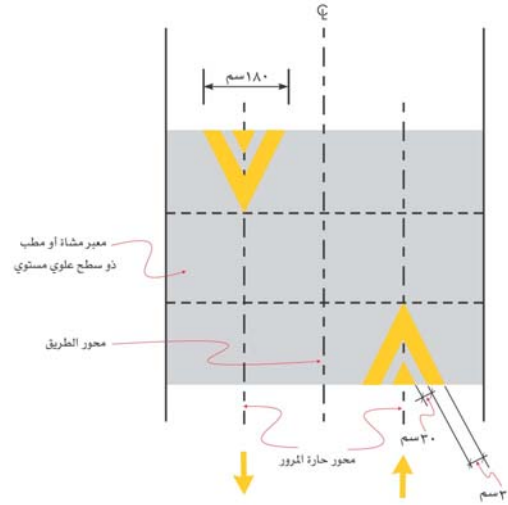

( ) : ( - - )

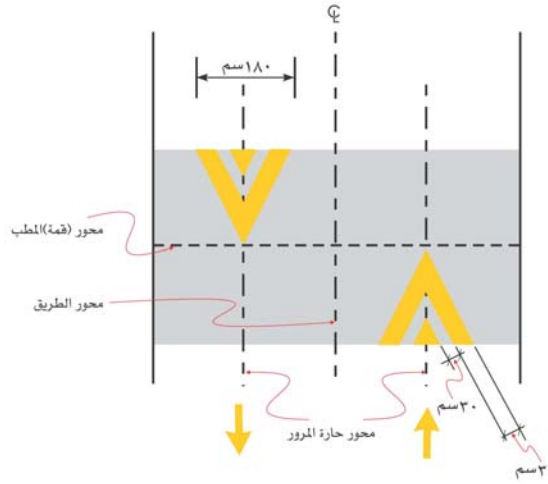

( ) : ( - - )

: -

" ( - - - )

" ( - - )

-



- ( )

( - - )

( )

( )

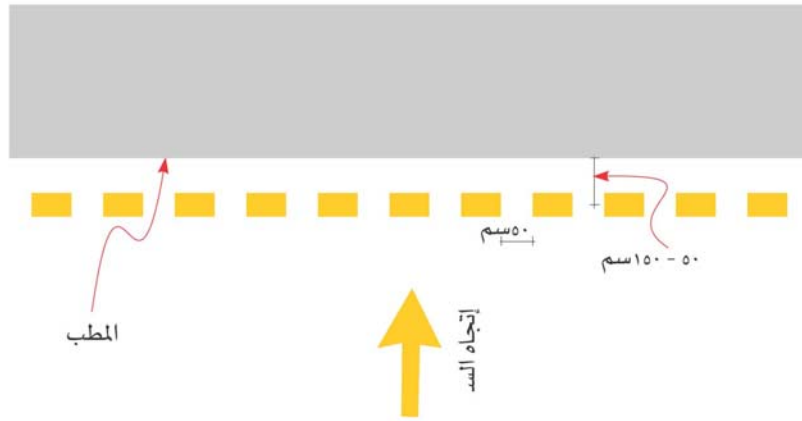

( )

:( - - )

: -

( )

: -

- ( ) -

4-Traffic Engineering Handbook- Institute of Transportation Engineers fifth edition-1999.

5-Traffic Calming State of Practice - Reid Ewin-FHWA-ITE-1999.

6-Traffic Calming Design Manual- Delaware Department of Transportation -August - 2000.

-